

Steering Configuration

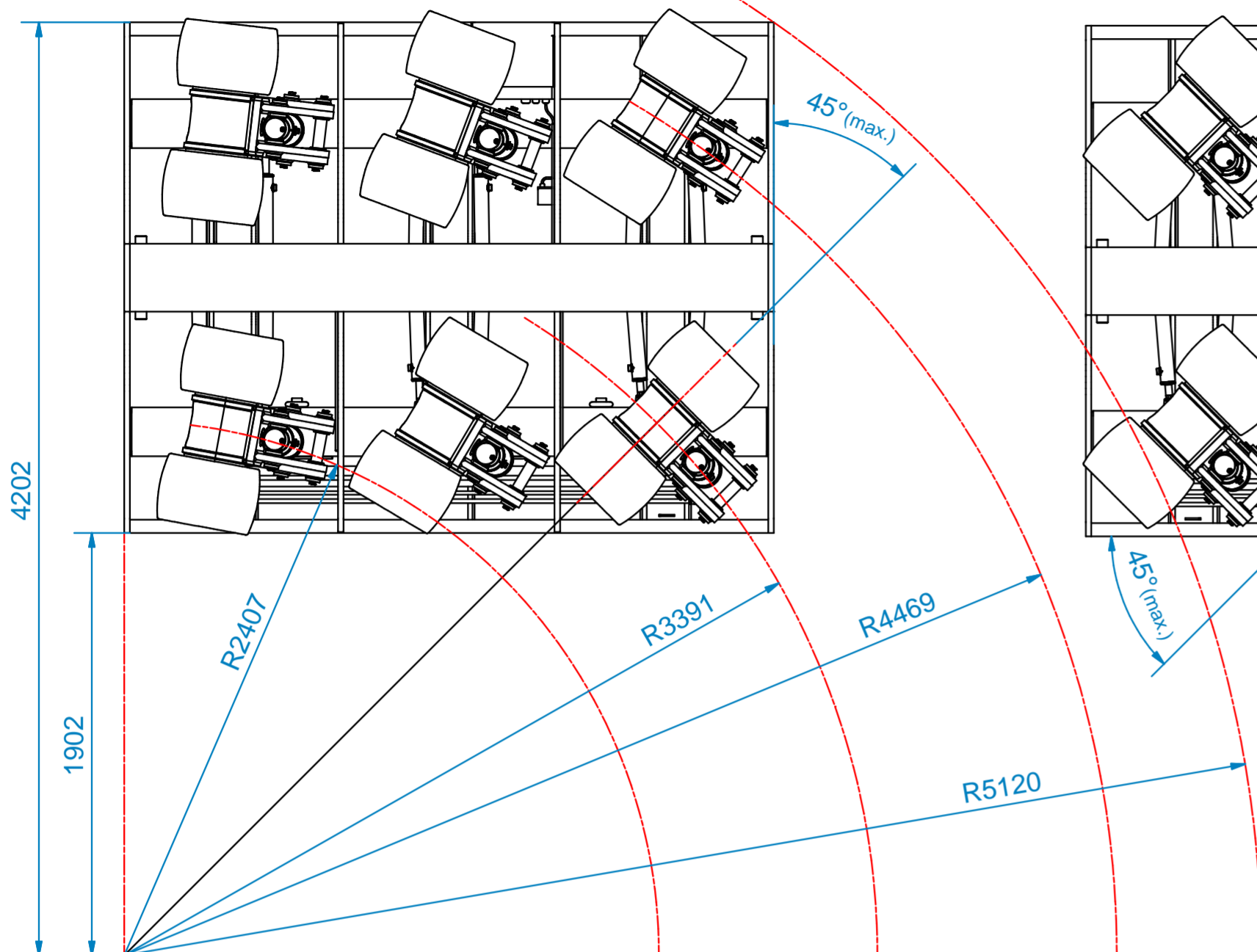

Crab Configuration

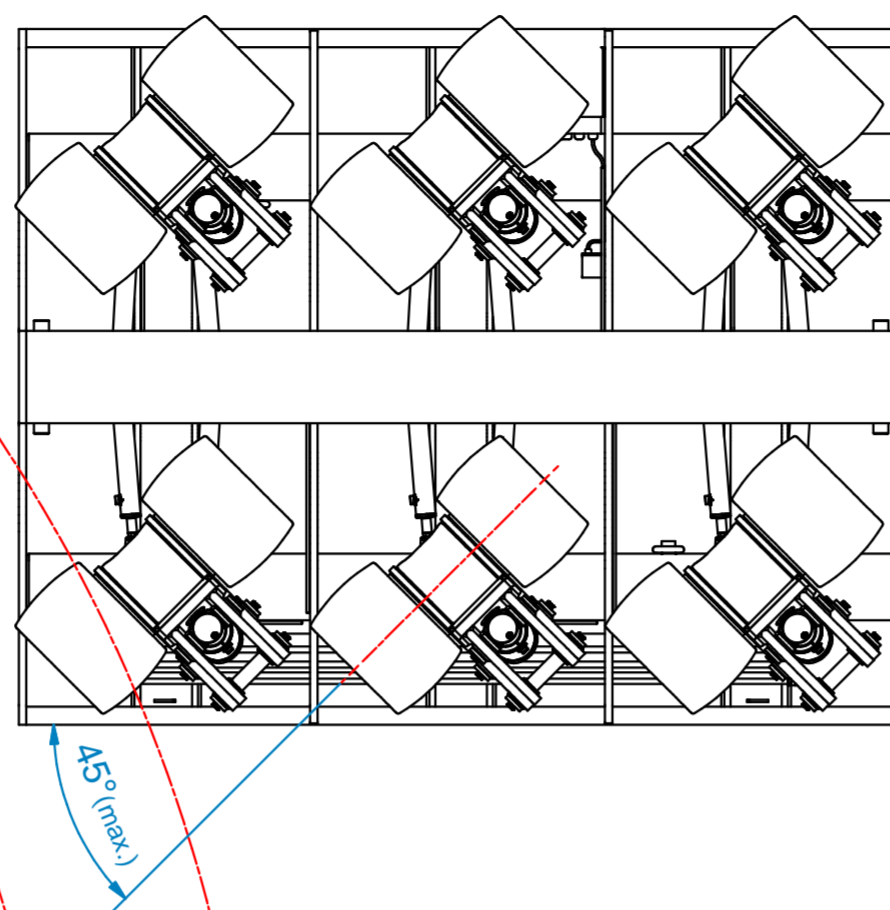

Steering Configuration (coupled)

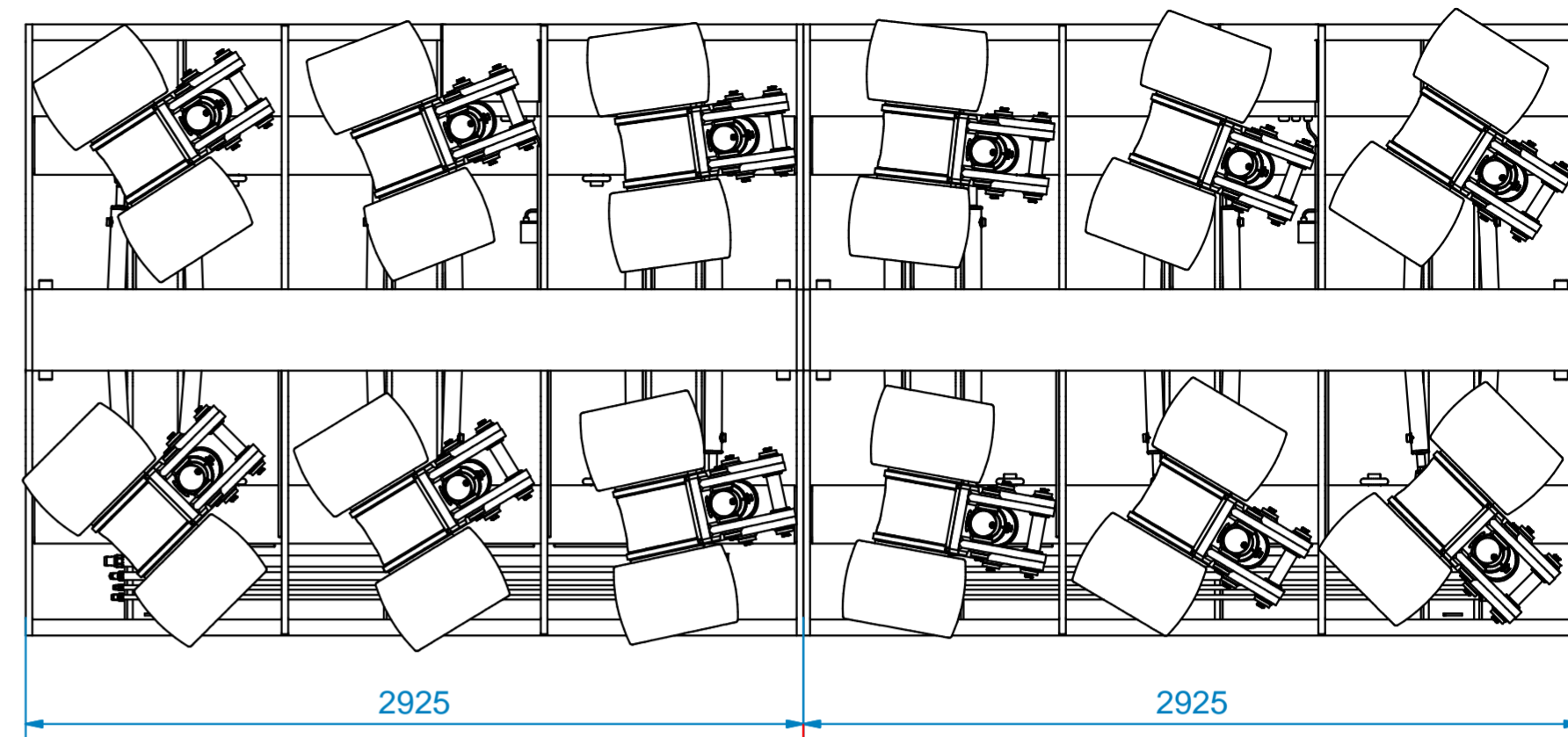

Allowed gap between units (modular configuration):

- 1 x length transporter: 2925 mm
- 2 x length transporter: 5850 mm
- 3 x length transporter: 8775 mm
- 4 x length transporter: 11700 mm

Total length can be up to 6 times trailer length,
Maximum configuration: 2 rows of 6 trailers: 12 trailers

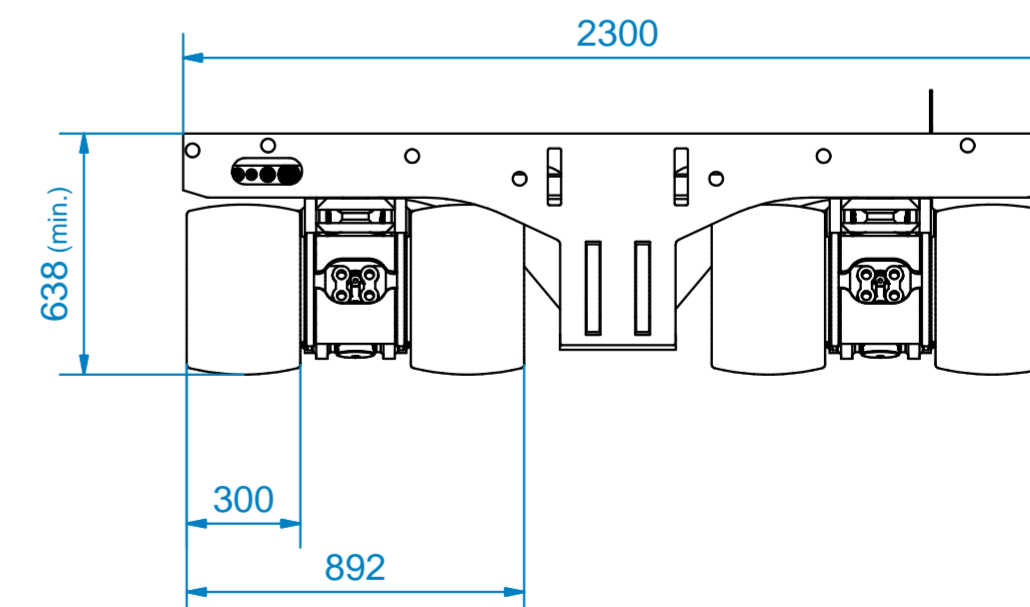
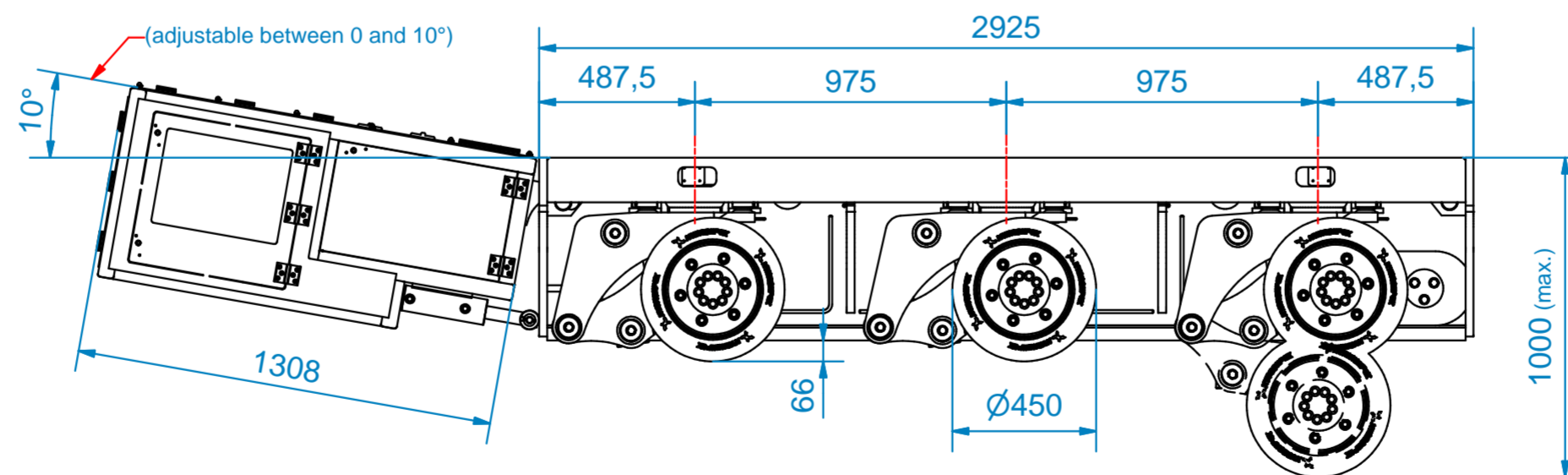
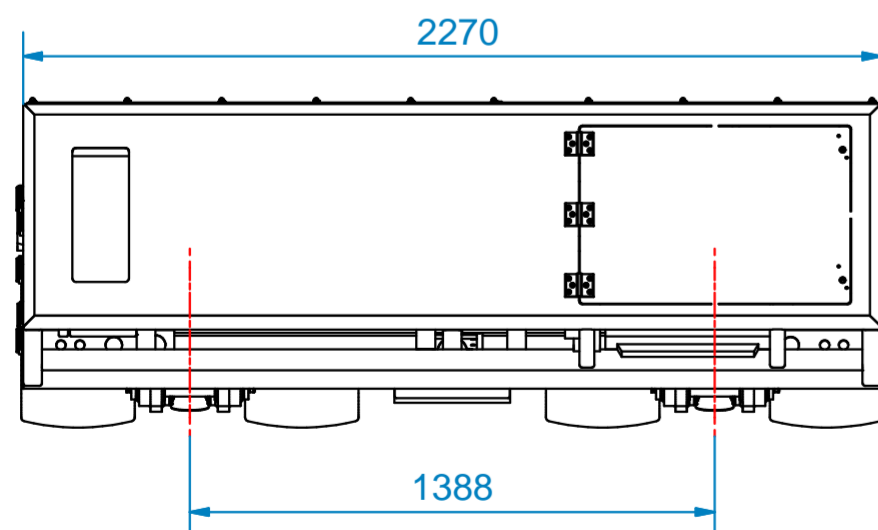
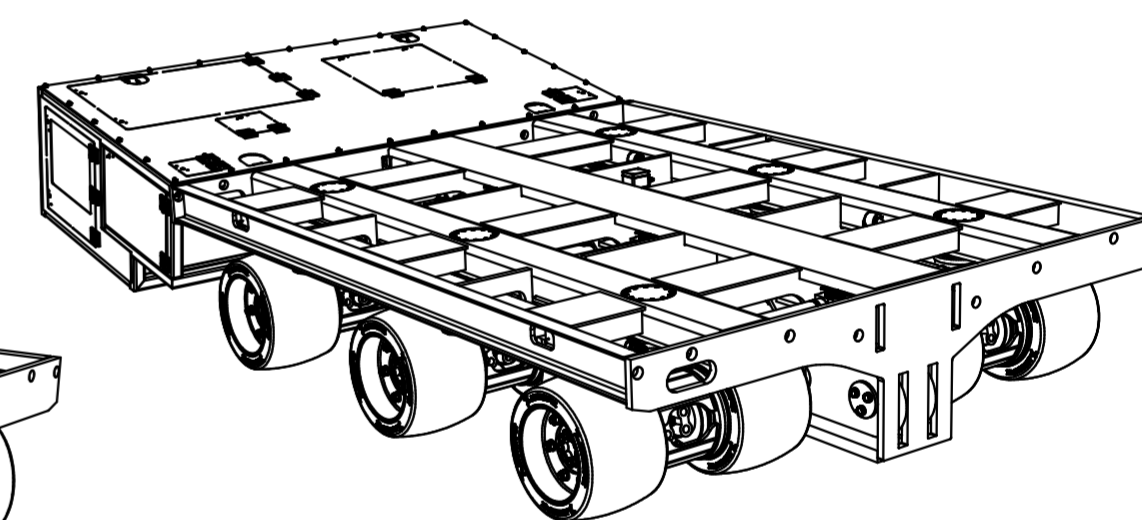
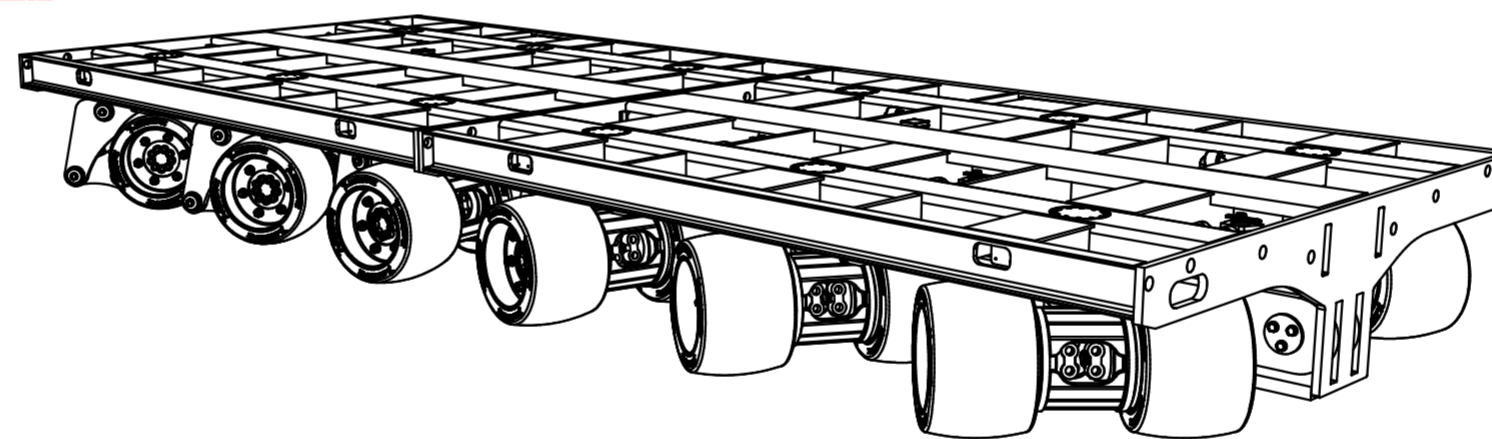

Features:

- Payload: 750 kN per trailer
- Self Weight: 6000 kg
- Speed: 5 km/h (unloaded)
- Speed: 2 km/h (loaded)
- Steering range: -45° to +45°
- Max. nos. of trailers: 2 rows of 6 trailers
- Power: 33 kW per Power Pack

DRAWN: C.K.	MASS: 6000 kg	MATERIAL:	REMOVE BURS OF INTERSECTING HOLES. BREAK SHARP EDGES. 0.1-0.3x45°	TOLERANCE UNLESS OTHERWISE STATED: ANGLE: ± 0.5° LINEAR: ± 0.5
DATE: 11/21/2007	SCALE: 1 : 20	APPROVED:	ROUGHNESS OVERALL: 3.2	PART NAME: HSPMT750
		OPAALSTRAAT 44, 7554 TS HENGELO HOLLAND PO BOX 421, 7550 AK HENGELO HOLLAND TELEPHONE 074-2420245 FACSIMILE 074-2430338 E-MAIL: INFO@HYDROSPEX.NL		DRAW. NO.: 02887.01.00.00
				REV. FROM: A2